



# HOW TO BUILD A SMALL VERTICAL SHAFT LIME KILN

AN EXAMPLE OF A CONTINUOUS PRODUCTION, MIXED FEED KILN  
FROM ZIMBABWE

## Introduction

In 1996 the Intermediate Technology Development Group (Now known as Practical Action) in partnership with G&W Industrial Minerals Pvt. (Ltd) built a continuous, mixed feed, vertical shaft lime kiln at Chegutu in Zimbabwe. Burning the calcitic limestone from Chegutu, this kiln can produce high-grade quicklime, which is suitable for metal processing, building, water purification and other purposes. The kiln works well and these notes give guidelines about how to build it. The notes are a practical guide to builders but naturally cannot deal with every detail. Also, we can only consider this particular size of kiln. Anyone who wants to build a bigger one should seek further advice. Vertical shaft kilns (VSKs) are not suitable for all types or sizes of limestone. Soft material will crush under the weight of stone in the shaft, and fine material will not allow enough air to flow through the kiln. So, lime burners must consider carefully before deciding if a VSK is the right choice of technology for them.



Figure 1: The vertical shaft kiln built for Practical Action in Chegutu, Zimbabwe. Photo: Kelvin Mason/ Practical Action.

## Design

The principle behind the design of shaft kilns is that the height of the shaft should be at least six times the diameter. The Chegutu kiln is designed for small-scale producers who want to start continuous production of high-grade lime with the minimum investment cost. It uses natural draught – there is no fan to ‘pump’ the air through the kiln. A chimney is used to provide enough natural draught and to take smoke away from the loading area where

people work. The fuel used at Chegutu is coal, but it is also possible to use charcoal and other solid fuels.

In general, shaft kilns use less fuel than batch kilns because less heat is wasted. In a shaft kiln there should be three 'zones'. At the bottom there is a cooling zone where incoming air passes through the quicklime. The air which is drawn in cools the quicklime so that less heat is wasted when the kiln is discharged. Also, the air which arrives in the firing zone is already warm which saves fuel. The firing zone is held about halfway up the kiln. In this zone the fuel is burning and the limestone is changing to quicklime. Above the firing zone the limestone is stored and warmed up. Using the waste heat from the firing zone to warm the limestone also saves fuel.

## Construction

### Materials

#### *Square brick skin*

Common bricks laid in mortar, 1:1:6 (Portland cement: hydrated lime: pit sand). Brick force for each fourth brick course. Brick force is standard brick reinforcing, consisting of two 2.5mm diameter longitudinal wires, connected by 2.5mm diameter cross wires at 300mm centres. The brick skin should be plastered with a lime plaster for weather protection, 1:5 (hydrated lime: pit sand).

#### *Circular shaft*

Refractory bricks laid in mortar of approximately 1:1 (refractory clay: refractory brick finely crushed).

#### *Concrete ring beam, slabs, slope at shaft floor, draw box and foundation*

1:1:5:5 (Portland cement: hydrated lime: river sand: 19mm limestone aggregate). Reinforcing as shown on drawing. The reinforcing is square twist steel with a yield strength of 410MPa. Ribbed steel of similar strength and same cross sectional area can be used instead depending on availability.

#### *Vermiculite concrete infill between the two brick skins*

Make a vermiculite mix, using 2 parts vermiculite and 1 part grog (finely crushed burned bricks). Use 1:4 (hydrated lime: vermiculite mix) to make up vermiculite concrete.

#### *Lime concrete infill below the floor of the kiln*

1:3:6 (hydrated lime: river sand: 75–100mm limestone aggregate).

#### *Tension bands*

50mm x 5mm flat straps on two sides, 12mm diameter mild steel rods with threaded ends on two sides.

#### *Inspection holes*

50mm diameter steel steam pipe, or similar, with 50mm flanges.

#### *Discharge door at draw box*

6mm mild steel shutter door set in steel frame as per drawing.

#### *Chimney*

2mm mild steel plate. 10mm diameter mild steel holding down bolts.

### Design assumptions

- Wind load is assumed for central Africa. In other parts of the world with different wind conditions, the chimney fixing should be checked.
- Soil conditions are assumed to be non-expansive soil, with good load bearing pressure, as would be the case in most limestone deposit areas. Difficult soil conditions or construction on sloping ground would require a special foundation design and further advice should be sought.

**Construction details**

The construction details, shown on the drawing, are largely as for the Chegutu kiln with some improvements. In addition the following should be noted:

- There should be no connection between the inner and outer brick skins above the draw box. This means the concrete platform at the top must be supported on the outer brick skin only and not touch the inner shaft. The steel chimney must be supported on the inner brick skin only. The chimney base plate extends over the edge of the concrete platform slab to prevent water from running into the gap between the two brick skins. Also, the vermiculite concrete infill must be cast with a paper joint between the surface of the inner brick shaft and the infill to allow the shaft to move separately from the outer casing.
- A brick course is assumed to be 90mm in height and a brick 230mm long, including mortar joints.
- The circular shaft is constructed in refractory bricks above the kiln floor. The bricks are laid as headers with overlapping vertical joints. They must be laid very tightly together on the internal face (see section B-B). Any mortar spilling from the joints should be cleaned off to give a smooth internal face.
- Refractory bricks have been chosen for the circular shaft to reduce the risk of abrasive and heat damage. These bricks are very expensive at approximately 12 times the cost of common bricks. An alternative may be to use refractory bricks only between courses 23 and 42. In this case, the lining may need to be replaced more often.
- Tension bands should be tightened gently, avoiding damage to the brick corners.
- Reinforcing bars are required for the concrete floor of the kiln, the draw box and the platform. The reinforcing required is shown on the drawing and listed in the bending schedule.
- The concrete should be cured well, keeping it wet for at least seven days. The slab can be covered with a layer of sand to help retain the moisture.
- Vermiculite concrete infill between the two brick skins should be cast in layers of no more than 1 metre in height.
- Inspection holes are also used for poking the lime during production and it is important that they are firmly fixed. Flanges have therefore been fitted to each end of the tubes.

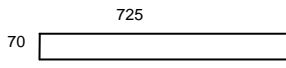
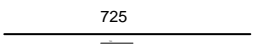
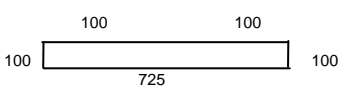
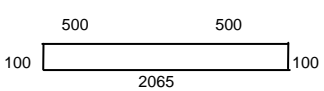
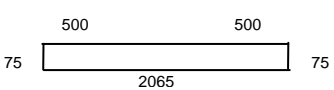
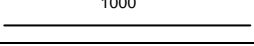
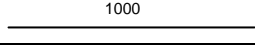
Bending schedule			
Bar mark	size	No of	Dimensions
01	10mm square twist	8	
02	10mm square twist	10	
03	10mm square twist	4	
04	10mm square twist	4	
05	10mm square twist	6	
06	10mm square twist	4	
07	10mm square twist	4	
Cover to reinforcement: 40mm			

technical brief

# technical brief

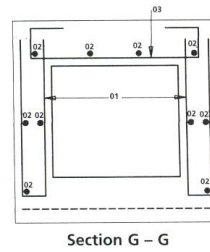
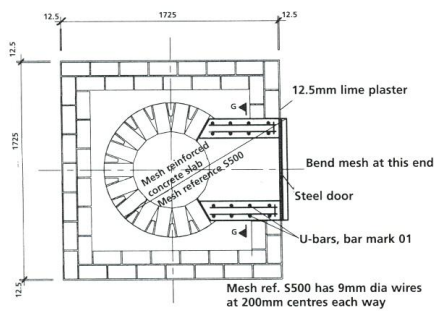
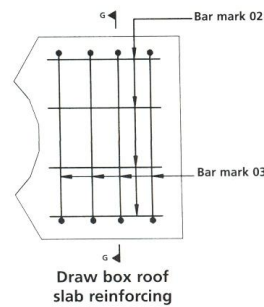
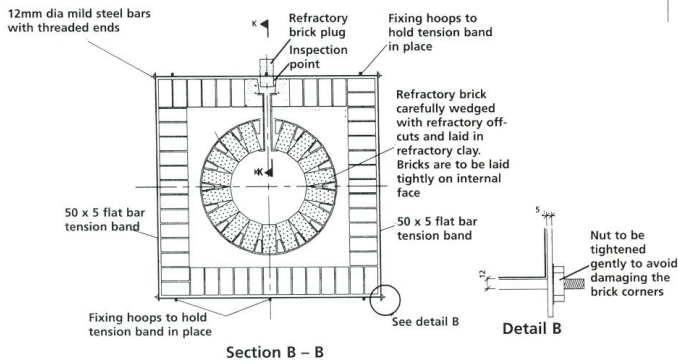
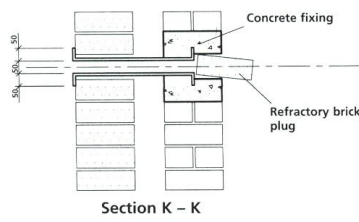
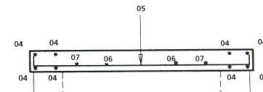
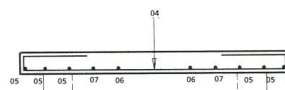
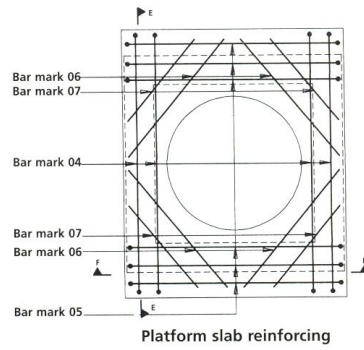

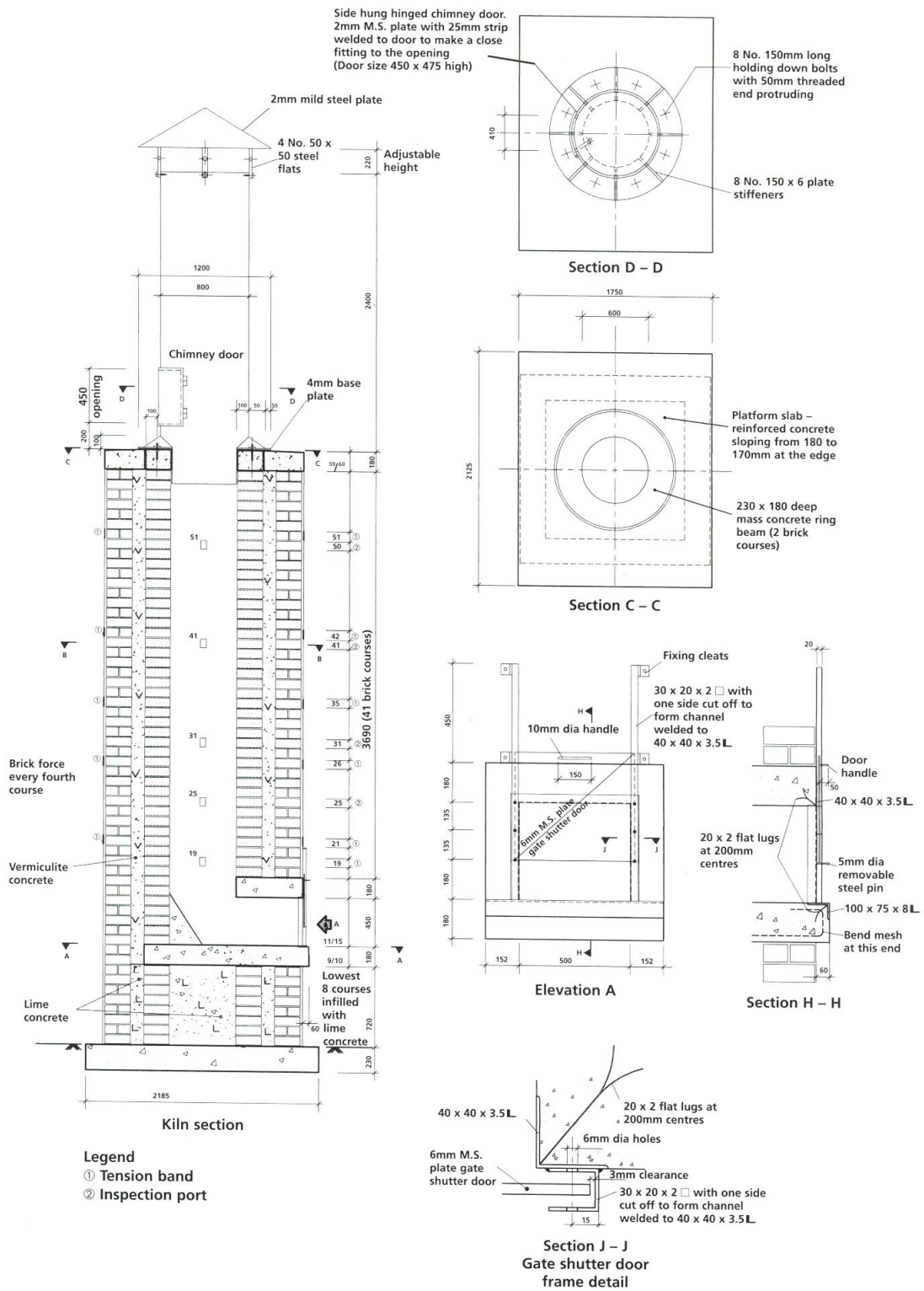

technical brief

**Kiln and ramp material quantities**

Item	Quantity / Size
Interface paper	1/3 roll (14.5m <sup>2</sup> )
Brickforce	105m x 230mm
Bricks	4000 units
Vermiculite	24 x 25kg
Refractory bricks	900 units
Fire clay	6 x 50kg
Cement	25 x 50kg
Chimney and chute	1 unit
Chimney holding down bolts	8 No. 10mm mild steel bolts, 150mm long
Inspection pipes	5 x 50mm dia. x 500mm
Reinforcement	8 x 5.5m; X12 x 26m; X10 x 23m
Reinforcing mesh	2m <sup>2</sup>
Discharge door and frame	480mm x 564mm x 6mm; 30mm x 20mm x 2mm x 2160mm square section
Discharge opening frame	40mm x 40mm x 3.5mm angle x 1480mm; 100mm x 100mm x 8mm x 805mm
Metal bands and tension rods	50mm x 5mm x 18.2m; 12mm dia. x 18m
Handrails	25mm x 25mm x 3mm x 11.5m tube; 50mm x 50mm x 5mm x 10m angle iron
Hydrated lime	15 x 50kg
Stone	3m <sup>3</sup>
River sand	3m <sup>3</sup>
Pit sand	3m <sup>3</sup>
Ramp, steelwork	25mm x 25mm x 3mm x 20m tube; 50mm x 50mm x 5mm x 18m angle iron
Ramp, boards	11 x 50mm x 152mm x 6300mm

**Infrastructure and accessories**

A ramp or hoist is needed to get limestone and fuel to the top of the kiln. If a hoist is used, then a cat ladder or stairs will be needed for worker access to the platform. The platform should be fitted with a safety handrail.

The Chegutu chimney is fitted with a swivel chute for loading the limestone. A simpler solution may be to use a loose chute.

Access to the inspection/poking holes can be provided by a portable ladder or a fixed cat ladder with protection hoops.

**Costing and quantities**

In 1996 the total cost of building the Chegutu Kiln was Z\$47,500 (approximately £2,700, excluding design and supervision costs). This cost was made up of Z\$36,500 for materials and Z\$7,000 for labour plus Z\$4,000 for infrastructure and accessories. Specified improvements are unlikely to increase costs by more than 10%.

The main costs were refractory bricks at 32% of the materials cost and the chimney at 25%. These are likely to remain the major costs for a similar kiln in any location.

**Programme**

For planning purposes, the following programme can be used:

- Day 1: Site clearance and excavation for foundation. Start fabrication of chimney plus any infrastructure and accessories.
- Day 2: Cast foundation slab.
- Day 3–10: Cure foundation slab.

- Day 11: Brick up to kiln floor slab.  
 Day 12: Fix floor slab reinforcing mesh and starter bars for draw box sides. Cast floor slab.  
 Day 13: Fix reinforcing, shutter and cast sides to the draw box. Cure floor slab.  
 Day 14: Shutter, fix reinforcing and cast roof of the draw box. Leave the side shutters in place. Cure floor slab and sides.  
 Day 15–21: Cure floor slab, draw box sides and roof slab.  
 Day 22–24: Build kiln shaft and outer casing, insert inspection pipes, fill cavity with vermiculite concrete. Leave the draw box shutter in place and prop the draw box roof slab.  
 Day 25–26: Cast shaft ring beam. Shutter, fix reinforcing and cast platform slab.  
 Day 27–31: Fix tension bands. Erect chimney and bolt in position. Plaster external kiln face. Remove draw box props and remove the shutters.  
 Day 32: Fix platform handrails. Complete infrastructure. Paint kiln metal work.

### Operation

Once the kiln has been lit, limestone – broken into suitable size pieces – is fed into the top with a measured amount of fuel: this process is called ‘mixed feed’. It is up to individual lime burners to decide the best size for their particular limestone and the quantity of fuel needed. The limestone travels down the shaft, burns and changes to quicklime. At regular times, cool quicklime is taken out of the bottom of the kiln. Fresh limestone and fuel is then loaded into the top.

### Capacity and output

When it is full, the kiln will hold about one and three quarter tonnes of limestone and coal. The daily output will be between 1 and 1 ½ tonnes of quicklime.

### Efficiency and fuel use

The efficiency of any lime burning process can be calculated using a formula. 2 For the Chegutu VSK it is possible to reach an efficiency of more than 40%.

As a brief practical guide, it has been found that the VSK in Chegutu produces good quality lime when the limestone to coal ratio is about 7.5:1. That is, for every tonne of coal used the kiln will burn about 7.5 tonnes of limestone. The stone used at Chegutu has a diameter between 100 and 140mm. The kiln is operated with the shutter door one third open. Lime burners will have to use their knowledge of their particular stone and experiment to find out how much fuel they need to produce quicklime which is well enough burned for their needs.

### References and further reading

- [Lime - An Introduction](#) Practical Action Technical Brief
- [Hydraulic Lime - An Introduction](#) Practical Action Technical Brief
- [Methods for testing lime in the field](#) Practical Action Technical Brief
- [How to calculate the Energy Efficiency of Lime Burning](#) Practical Action Technical Brief
- [Testing methods for pozzolanas](#) Practical Action Technical Brief
- [Lime Kiln Designs: Small & Medium Scale Oil Fired Lime Kilns](#) Practical Action Technical Brief
- [A Small Lime Kiln for Batch and Continuous Firing](#) Practical Action Technical Brief
- [The Small Scale Vertical Shaft Lime Kiln: A practical guide to design, construction and operation](#), Kelvin Mason, Practical Action Publishing, ISBN 9781853394652
- [Small-scale Lime-burning: A practical introduction](#) Michael Wingate, Practical Action Publishing, ISBN 9780946688012
- [A Case Study in Lime Production No2 Improved Techniques at Chenkumbi, Malawi](#), Practical Action Technical Brief
- [Lime and Alternative Binders in East Africa](#) Elijah Agevi et al, Practical Action

- /ODA, 1995
- [Lime and Other Alternative Cements](#) Neville Hill et al, Practical Action Publishing, 1992
- [Building with Lime: A practical introduction. Revised Edition](#) Stafford Holmes & Michael Wingate, Practical Action Publishing, 2002/3 ISBN 9781853395475
- [Guide for Manufacture of Lime in Vertical Mixed-feed type lime kiln: Part 1 From lime-stone](#), Indian Standard IS 1861 Part 1 – 1990, Bureau of Indian Standards, New Delhi, India

This technical brief was originally produced for **basin**, Building Advisory Service and Information and was prepared by Chris Stevens of Paragon Ceramics Ltd. (PO Box 54, Dedza, Malawi) and Kelvin Mason, a consultant to ITDG (now Practical Action).

Practical Action would like to thank the lime burners who assisted with the design of this kiln.

Practical Action  
The Schumacher Centre  
Bourton-on-Dunsmore  
Warwickshire, CV23 9QZ  
United Kingdom  
Tel: +44 (0)1926 634400  
Fax: +44 (0)1926 634401  
E-mail: [inforsew@practicalaction.org.uk](mailto:inforsew@practicalaction.org.uk)  
Website: <http://practicalaction.org/practicalanswers/>

*This Technical Brief is possible thanks to the collaboration of DFID-UK and The Tony Bullard Trust.*

Practical Action is a development charity with a difference. We know the simplest ideas can have the most profound, life-changing effect on poor people across the world. For over 40 years, we have been working closely with some of the world's poorest people - using simple technology to fight poverty and transform their lives for the better. We currently work in 15 countries in Africa, South Asia and Latin America.

technical brief